

BuzziSpark

Electrification Unit 220 - 240V

INSTALLATION MANUAL

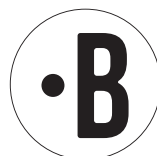
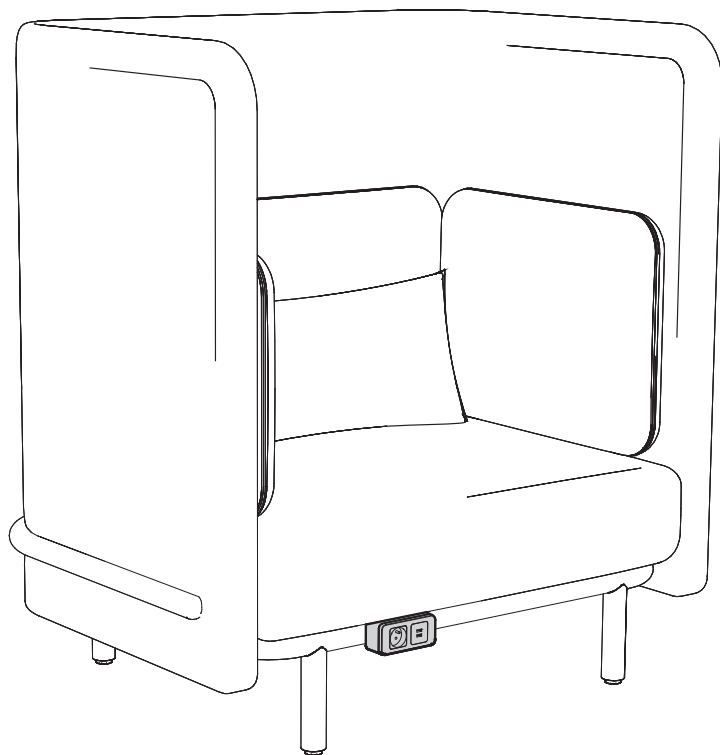

Technical info

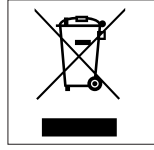
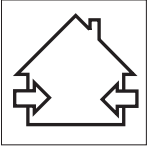

Environmental Protection

Waste electrical products should not be disposed of with household waste. Please recycle where facilities exist. Check with your Local Authority or retailer for recycling advice.

France / Belgium

Article reference: P0179-ELEC.01
1 x Socket outlet: 250Vac / 16A
Type E (BE/FR/PO/SL)
Max 3500W
Pen earthing
Child safety mechanism included
2 x USB outlet: USB-connector Type A
Max. combined output 2.1A, 5V DC (10.5VA)
Cable: Length 3 m - black
Cable type 3G1,5 mm²
Plug type – angled Type E & F hybrid CEE 7/7
Certification: CE
Color: Black
Dimensions front: 137 x 63 mm

Germany / Netherlands

Article reference: P0179-ELEC.02
1 x Socket outlet: 250Vac / 16A
Type F (Schuko - DE/NL/SP/NO/SW)
Max 3500W
Side earthing
Child safety mechanism included
2 x USB outlet: USB-connector Type A
Max. combined output 2.1A, 5V DC (10.5VA)
Cable: Length 3 m - black
Cable type 3G1,5 mm²
Plug type – angled Type E & F hybrid CEE 7/7
Certification: CE
Color: Black
Dimensions front: 137 x 63 mm

UK

Article reference: P0179-ELEC.03
1 x Socket outlet: 250Vac / 13A
Type G (UK/IR/MA)
GB-Y fused 3,15A
Child safety mechanism included
2 x USB outlet: USB-connector Type A
Max. combined output 2.1A, 5V DC (10.5VA)
Cable: Length 3 m - black
Cable type 3G1,5 mm²
Plug type G – 13A
Certification: CE
Color: Black
Dimensions front: 137 x 63 mm

BuzziSpark Tablet

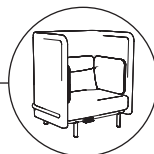

1 PERS. 

Included

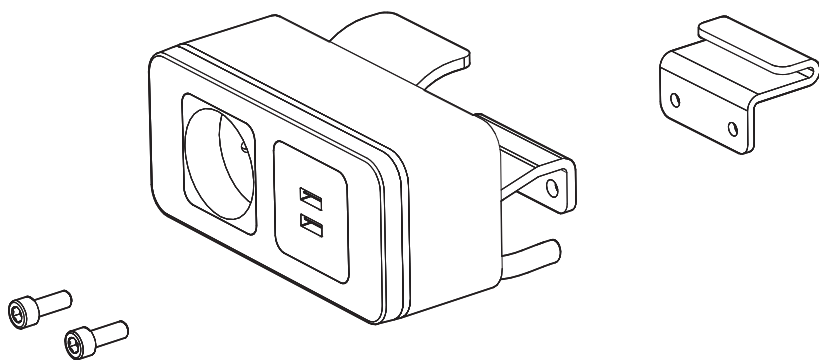

1

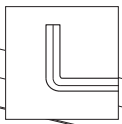
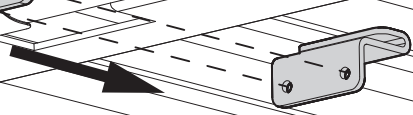
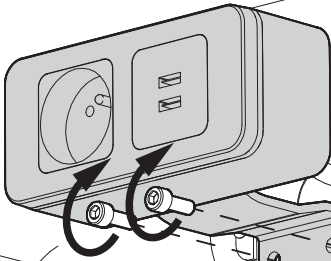
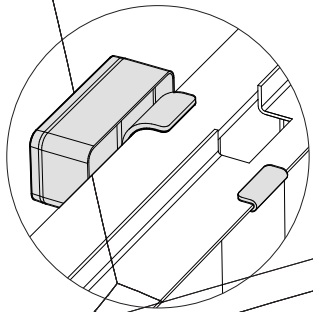

2

France / Belgium

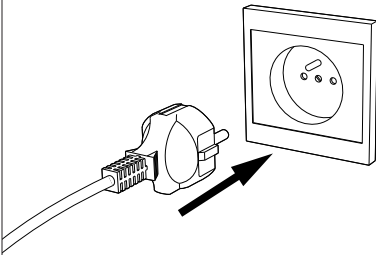

Germany / Netherlands

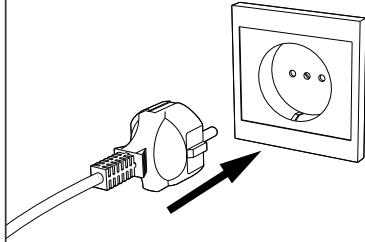

UK

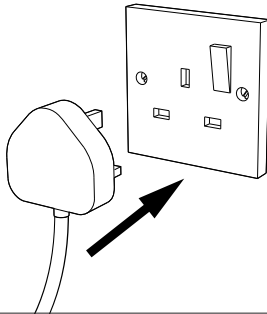

BuzziSpace
Groeningenlei 141
2550 Antwerp, Kontich
Belgium
☎ +32 (0)3 846 10 00
✉ info@buzzi.space
🌐 www.buzzi.space



Doc nr.: A-0000006456
Last update: 10/05/2019